

PRODUCT & PRICING INFO CONTACT

STREETSCAPES

STREETSCAPES.BIZ

Info@streetscapefurniture.com ■ 303.398.7040

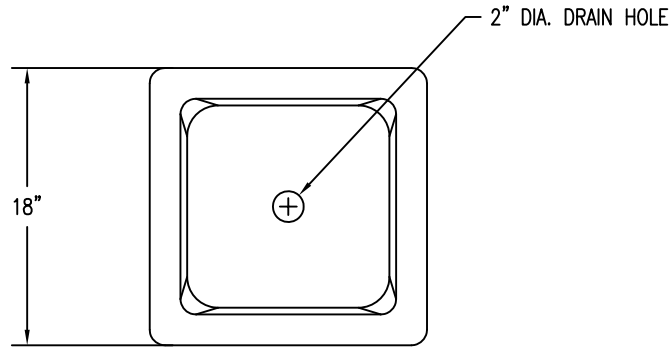

1 TOP VIEW

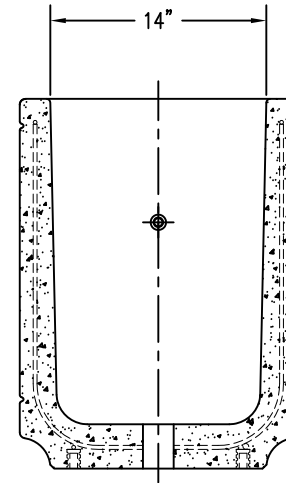

4 CROSS SECTION

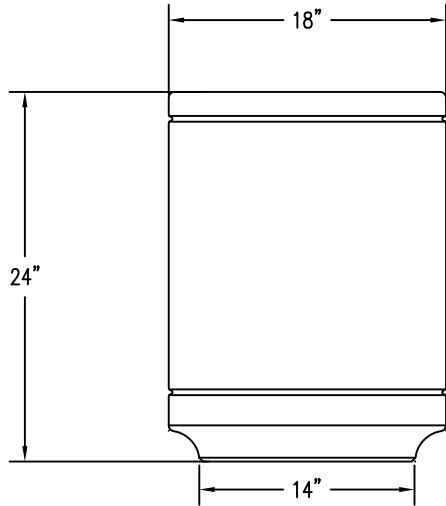

2 ELEVATION VIEW

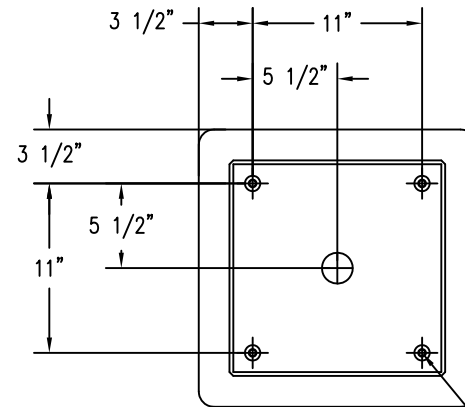

3 BOTTOM VIEW

1/2-13 S/S INSERT
(4) REQ'D

WAUSAU MADE

REVISIONS

1	NAME	DATE	NOTES
2			
3			
4			
5			
6			
7			
8			

CONFIDENTIAL INFORMATION
 THESE DRAWING, SPECIFICATIONS AND OTHER INFORMATION AND DOCUMENTS ACCOMPANYING THEM ARE THE CONFIDENTIAL AND PROPRIETARY PROPERTY OF WAUSAU TILE, INC. THE DRAWINGS THEMSELVES SHALL BELONG TO THE OWNER FOR USE ONLY ON THE PROJECT. ANY ADDITIONAL USE SHALL REQUIRE THE PRIOR WRITTEN APPROVAL OF WAUSAU TILE, INC. THE PROPRIETARY INFORMATION CONTAINED WITHIN THE DRAWINGS AND THE DOCUMENTS IS AND SHALL REMAIN THE SOLE PROPERTY OF WAUSAU TILE, INC.

JOB NAME

ADDRESS
CITY, STATE ZIP

UNLESS OTHERWISE SPECIFIED
DIMENSIONS ARE IN INCHES
FRACTIONS ±1/8"

DRAWN BY: SK

DATE: 7/23/15

CO NUMBER: ?

WEIGHT: 390 LBS

PRODUCT NO.

TF 4185

PRODUCT & PRICING INFO CONTACT



STREETSCAPES.BIZ

Info@streetscapefurniture.com ■ 303.398.7040

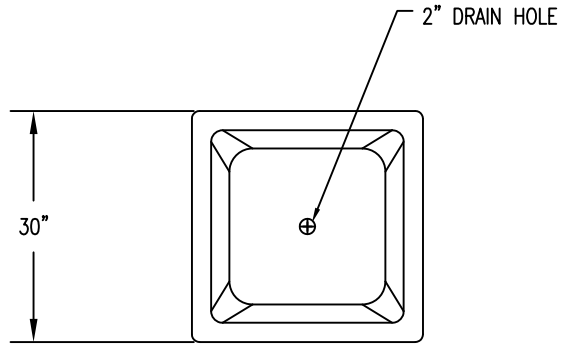

1 TOP VIEW

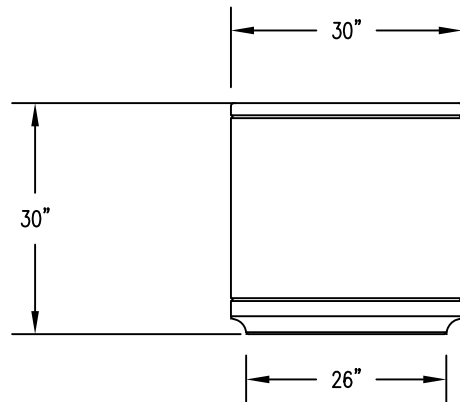

2 ELEVATION VIEW

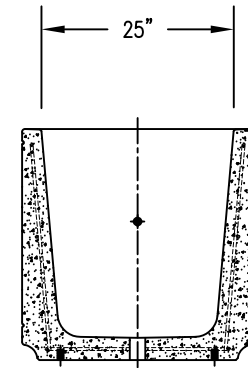

4 CROSS SECTION

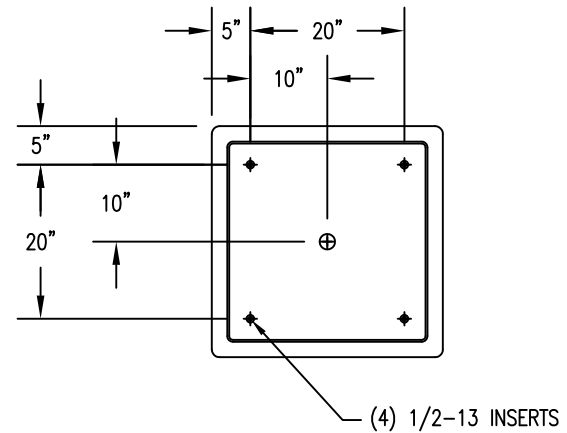

3 BOTTOM VIEW



REVISIONS

NAME	DATE	NOTES
1		
2		
3		
4		
5		
6		
7		
8		

CONFIDENTIAL INFORMATION
 THESE DRAWING, SPECIFICATIONS AND OTHER INFORMATION AND DOCUMENTS ACCOMPANYING THEM ARE THE CONFIDENTIAL AND PROPRIETARY PROPERTY OF WAUSAU TILE, INC. THE DRAWINGS THEMSELVES SHALL BELONG TO THE OWNER FOR USE ONLY ON THE PROJECT. ANY ADDITIONAL USE SHALL REQUIRE THE PRIOR WRITTEN APPROVAL OF WAUSAU TILE, INC. THE PROPRIETARY INFORMATION CONTAINED WITHIN THE DRAWINGS AND THE DOCUMENTS IS AND SHALL REMAIN THE SOLE PROPERTY OF WAUSAU TILE, INC.

JOB NAME
 ADDRESS
 CITY, STATE ZIP

UNLESS OTHERWISE SPECIFIED
 DIMENSIONS ARE IN INCHES
 FRACTIONS 1/8"

DRAWN BY: SK
 DATE: 7/23/15
 CO NUMBER: ?
 WEIGHT: 1,060 LBS

PRODUCT NO.
 TF 4190

PRODUCT & PRICING INFO CONTACT



Info@streetscapefurniture.com ■ 303.398.7040

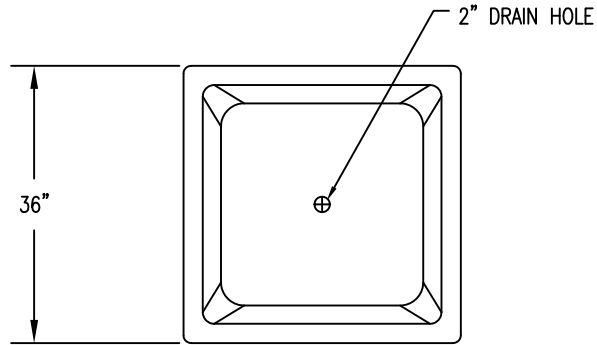

1 TOP VIEW

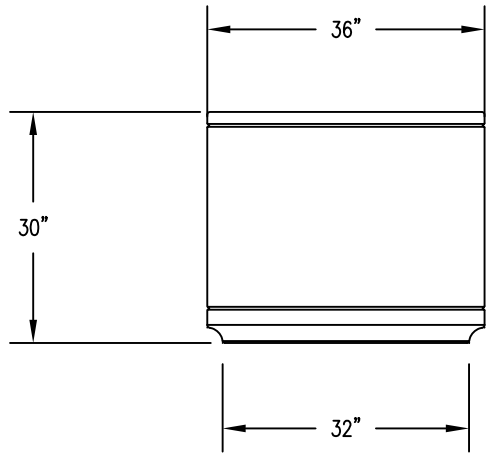

2 ELEVATION VIEW

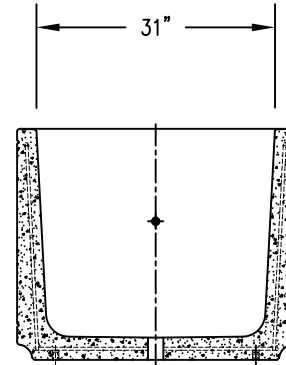

4 CROSS SECTION

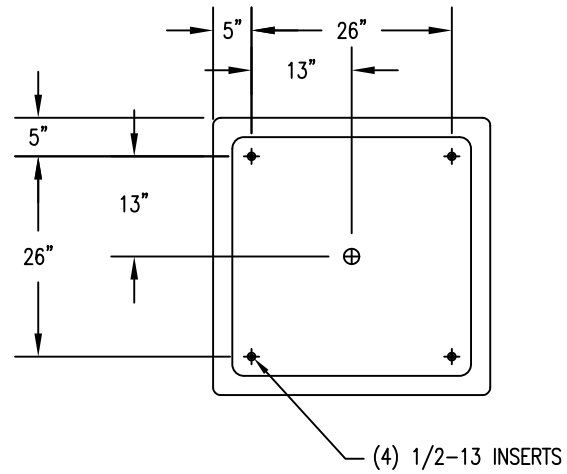

3 BOTTOM VIEW

WAUSAU MADE

REVISIONS

NAME	DATE	NOTES
1		
2		
3		
4		
5		
6		
7		
8		

CONFIDENTIAL INFORMATION
 THESE DRAWING, SPECIFICATIONS AND OTHER INFORMATION AND DOCUMENTS ACCOMPANYING THEM ARE THE CONFIDENTIAL AND PROPRIETARY PROPERTY OF WAUSAU TILE, INC. THE DRAWINGS THEMSELVES SHALL BELONG TO THE OWNER FOR USE ONLY ON THE PROJECT. ANY ADDITIONAL USE SHALL REQUIRE THE PRIOR WRITTEN APPROVAL OF WAUSAU TILE, INC. THE PROPRIETARY INFORMATION CONTAINED WITHIN THE DRAWINGS AND THE DOCUMENTS IS AND SHALL REMAIN THE SOLE PROPERTY OF WAUSAU TILE, INC.

JOB NAME
 ADDRESS
 CITY, STATE ZIP

UNLESS OTHERWISE SPECIFIED
 DIMENSIONS ARE IN INCHES
 FRACTIONS ±1/8"

DRAWN BY: SK
 DATE: 7/23/15
 CO NUMBER: ?
 WEIGHT: 1,200 LBS

PRODUCT NO.
 TF 4195

PRODUCT & PRICING INFO CONTACT

STREETSCAPES

STREETSCAPES.BIZ

Info@streetscapefurniture.com ■ 303.398.7040

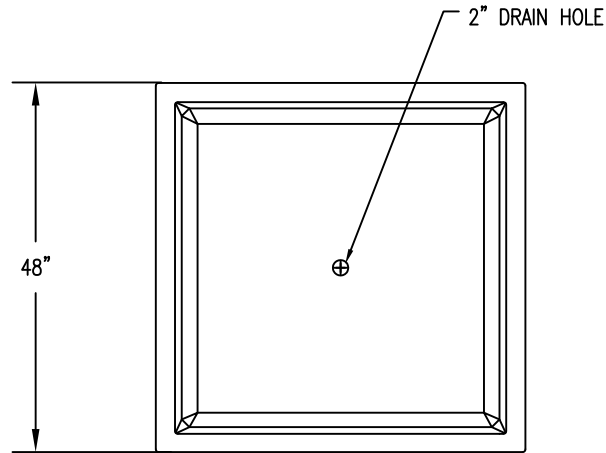

1 TOP VIEW

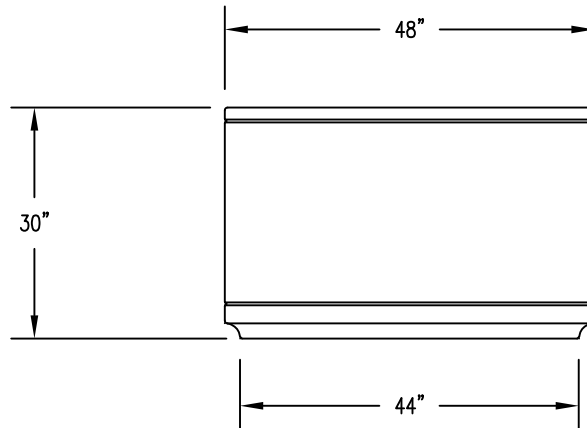

2 ELEVATION VIEW

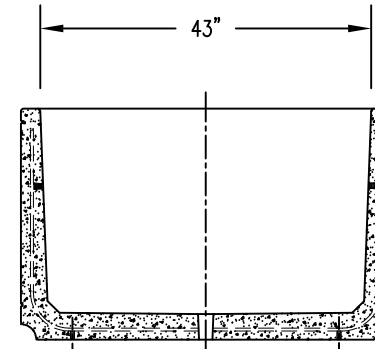

4 CROSS SECTION

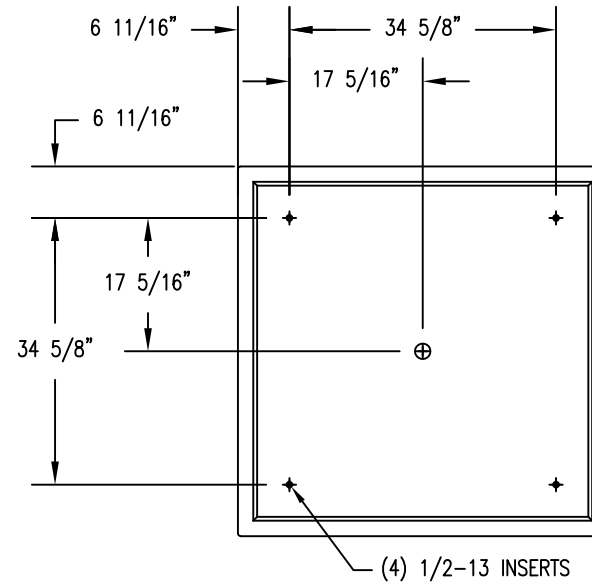

3 BOTTOM VIEW

WAUSAU MADE

REVISIONS

NAME	DATE	NOTES
1		
2		
3		
4		
5		
6		
7		
8		

CONFIDENTIAL INFORMATION
 THESE DRAWING, SPECIFICATIONS AND OTHER INFORMATION AND DOCUMENTS ACCOMPANYING THEM ARE THE CONFIDENTIAL AND PROPRIETARY PROPERTY OF WAUSAU TILE, INC. THE DRAWINGS THEMSELVES SHALL BELONG TO THE OWNER FOR USE ONLY ON THE PROJECT. ANY ADDITIONAL USE SHALL REQUIRE THE PRIOR WRITTEN APPROVAL OF WAUSAU TILE, INC. THE PROPRIETARY INFORMATION CONTAINED WITHIN THE DRAWINGS AND THE DOCUMENTS IS AND SHALL REMAIN THE SOLE PROPERTY OF WAUSAU TILE, INC.

JOB NAME
 ADDRESS
 CITY, STATE ZIP

UNLESS OTHERWISE SPECIFIED
 DIMENSIONS ARE IN INCHES
 FRACTIONS ±1/8"

DRAWN BY: SK
 DATE: 7/23/15
 CO NUMBER: ?
 WEIGHT: 1,960 LBS

PRODUCT NO.
 TF 4200

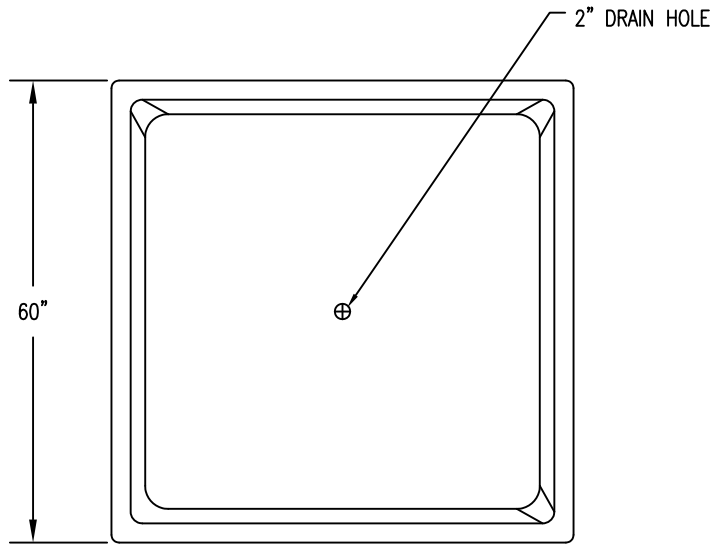

1 TOP VIEW

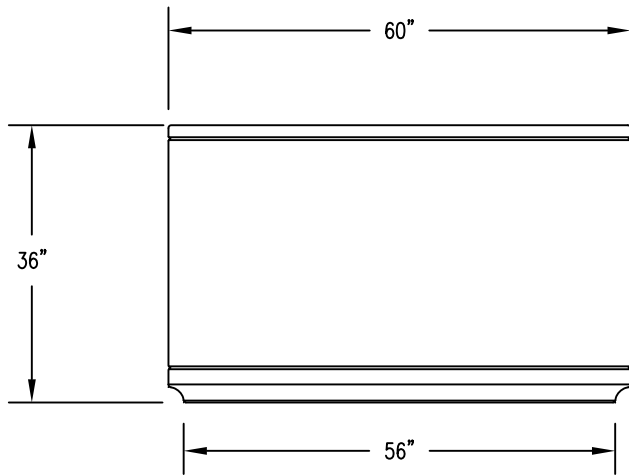

2 ELEVATION VIEW

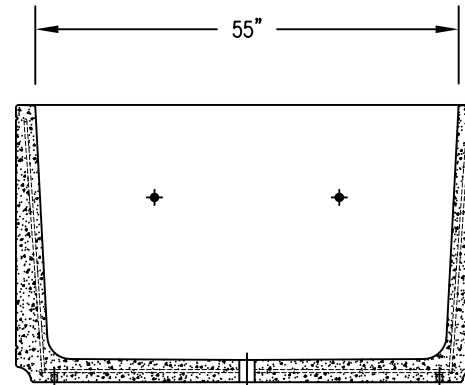

4 CROSS SECTION

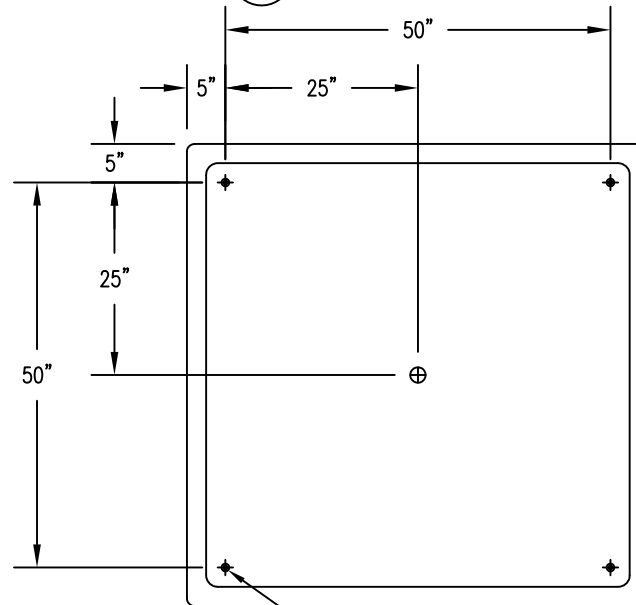

(4) 1/2-13 INSERTS

3 BOTTOM VIEW

REVISIONS

NAME	DATE	NOTES
1		
2		
3		
4		
5		
6		
7		
8		

CONFIDENTIAL INFORMATION
THESE DRAWING, SPECIFICATIONS AND OTHER INFORMATION AND DOCUMENTS ACCOMPANYING THEM ARE THE CONFIDENTIAL AND PROPRIETARY PROPERTY OF WAUSAU TILE, INC. THE DRAWINGS THEMSELVES SHALL BELONG TO THE OWNER FOR USE ONLY ON THE PROJECT. ANY ADDITIONAL USE SHALL REQUIRE THE PRIOR WRITTEN APPROVAL OF WAUSAU TILE, INC. THE PROPRIETARY INFORMATION CONTAINED WITHIN THE DRAWINGS AND THE DOCUMENTS IS AND SHALL REMAIN THE SOLE PROPERTY OF WAUSAU TILE, INC.

JOB NAME
ADDRESS
CITY, STATE ZIP

UNLESS OTHERWISE SPECIFIED
DIMENSIONS ARE IN INCHES
FRACTIONS ±1/8"

DRAWN BY: SK
DATE: 7/23/15
CO NUMBER: ?
WEIGHT: 3,470 LBS

PRODUCT NO.
TF 4205

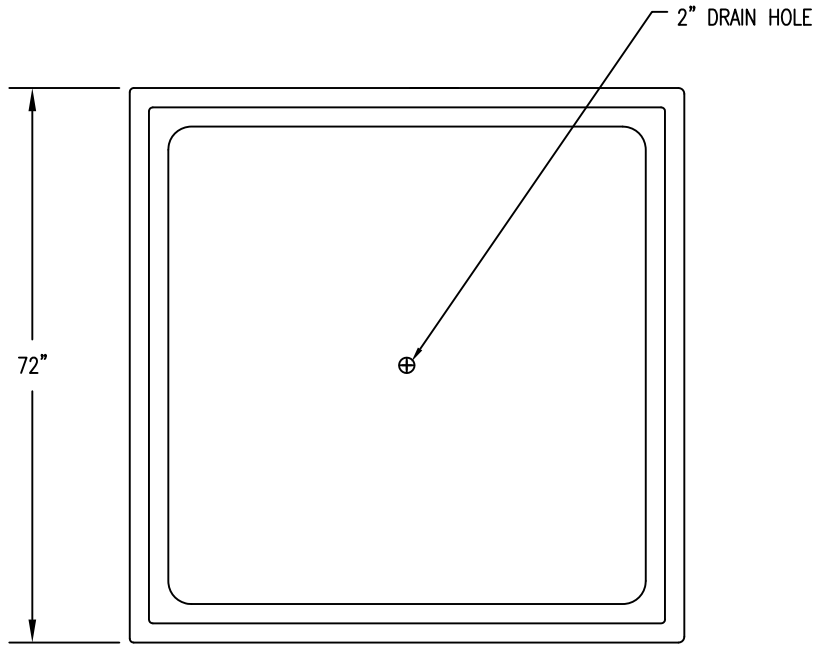

1 TOP VIEW

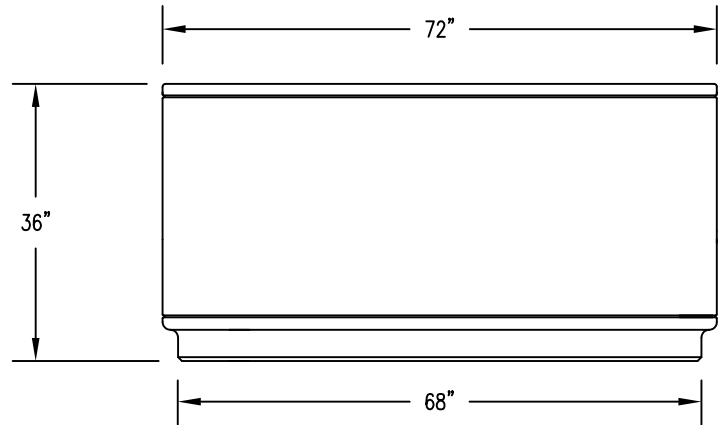

2 ELEVATION VIEW

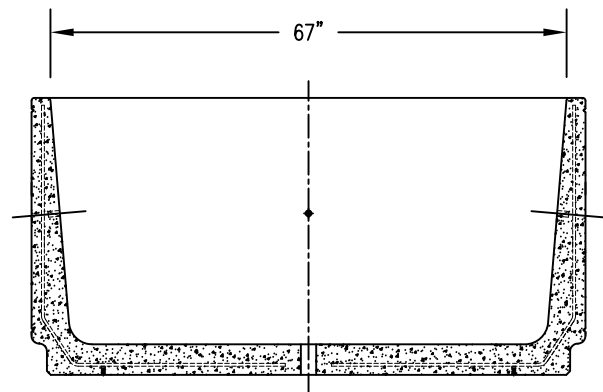

4 CROSS SECTION

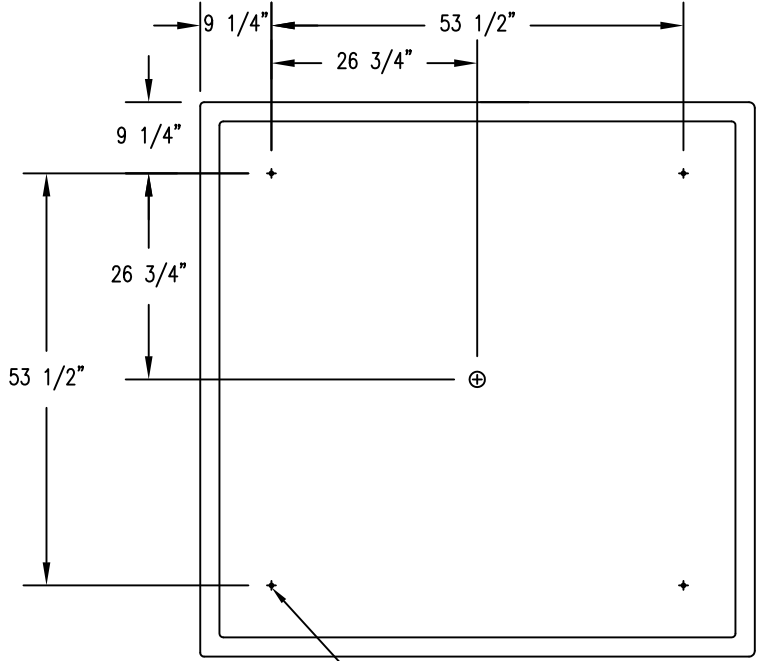

3 BOTTOM VIEW

(4) 1/2-13 INSERTS

REVISIONS		
NAME	DATE	NOTES
1		
2		
3		
4		
5		
6		
7		
8		

CONFIDENTIAL INFORMATION
 THESE DRAWING, SPECIFICATIONS AND OTHER INFORMATION AND DOCUMENTS ACCOMPANYING THEM ARE THE CONFIDENTIAL AND PROPRIETARY PROPERTY OF WAUSAU TILE, INC. THE DRAWINGS THEMSELVES SHALL BELONG TO THE OWNER FOR USE ONLY ON THE PROJECT. ANY ADDITIONAL USE SHALL REQUIRE THE PRIOR WRITTEN APPROVAL OF WAUSAU TILE, INC. THE PROPRIETARY INFORMATION CONTAINED WITHIN THE DRAWINGS AND THE DOCUMENTS IS AND SHALL REMAIN THE SOLE PROPERTY OF WAUSAU TILE, INC.

JOB NAME
 ADDRESS
 CITY, STATE ZIP

UNLESS OTHERWISE SPECIFIED
 DIMENSIONS ARE IN INCHES
 FRACTIONS ±1/8"

DRAWN BY: SK
 DATE: 7/23/15
 CO NUMBER: ?
 WEIGHT: 4,600 LBS

PRODUCT NO.
TF 4209

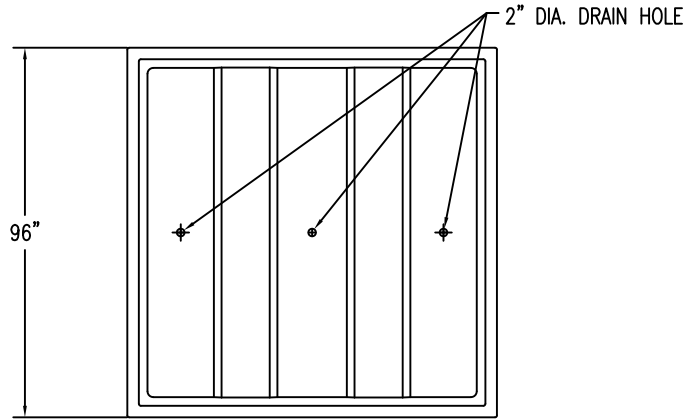

1 TOP VIEW

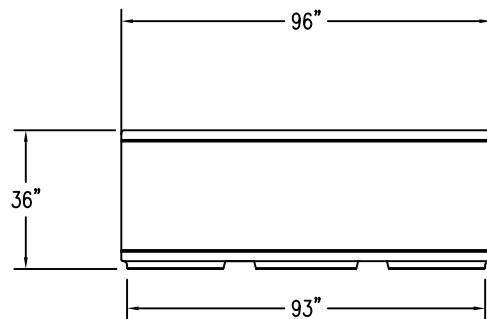

2 ELEVATION VIEW

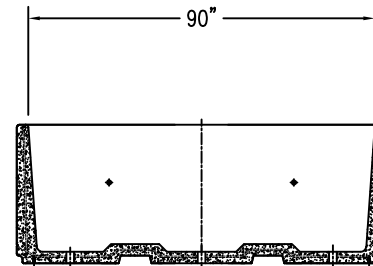

4 CROSS SECTION

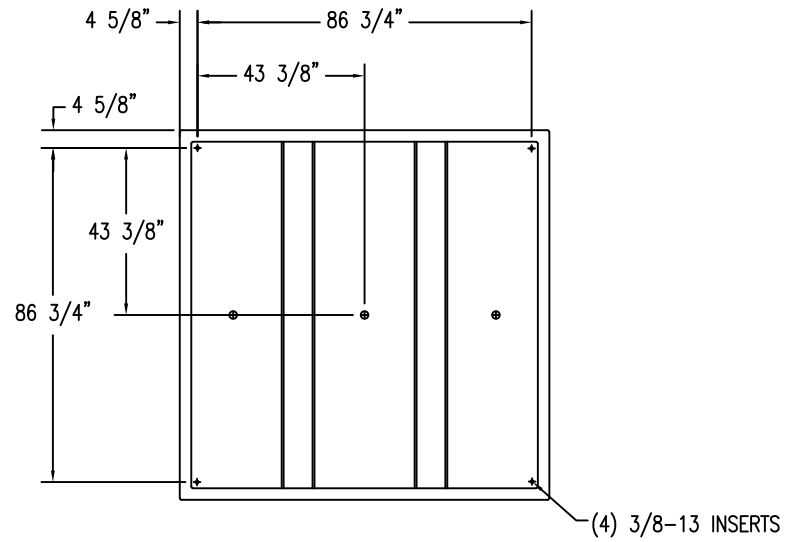

3 BOTTOM VIEW

REVISIONS

NAME	DATE	NOTES
1		
2		
3		
4		
5		
6		
7		
8		

CONFIDENTIAL INFORMATION
 THESE DRAWING, SPECIFICATIONS AND
 OTHER INFORMATION AND DOCUMENTS
 ACCOMPANYING THEM ARE THE
 CONFIDENTIAL AND PROPRIETARY PROPERTY
 OF WAUSAU TILE, INC. THE DRAWINGS
 THEMSELVES SHALL BELONG TO THE
 OWNER FOR USE ONLY ON THE PROJECT.
 ANY ADDITIONAL USE SHALL REQUIRE THE
 PRIOR WRITTEN APPROVAL OF WAUSAU
 TILE, INC. THE PROPRIETARY INFORMATION
 CONTAINED WITHIN THE DRAWINGS AND
 THE DOCUMENTS IS AND SHALL REMAIN
 THE SOLE PROPERTY OF WAUSAU TILE, INC.

JOB NAME

ADDRESS
 CITY, STATE ZIP

UNLESS OTHERWISE SPECIFIED
 DIMENSIONS ARE IN INCHES
 FRACTIONS ±1/8"

DRAWN BY: SK
 DATE: 7/22/15
 CD NUMBER: ?
 WEIGHT: 6,900 LBS

PRODUCT NO.
TF 4214