

PRODUCT & PRICING INFO CONTACT

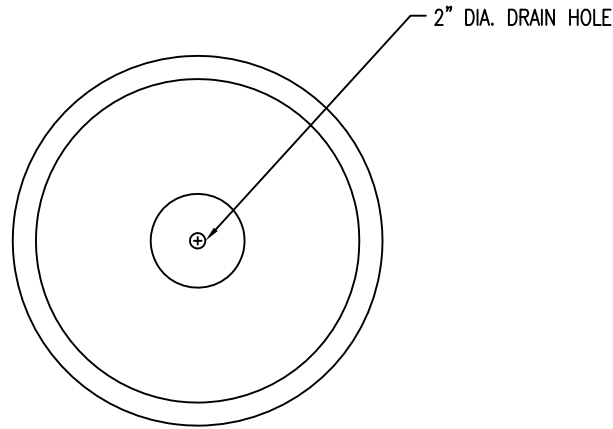

STREETSCAPES.BIZ

Info@streetscapefurniture.com ■ 303.398.7040



1 TOP VIEW

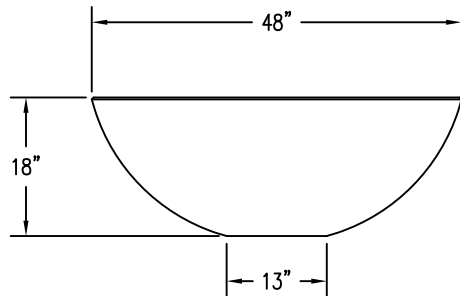

2 ELEVATION VIEW

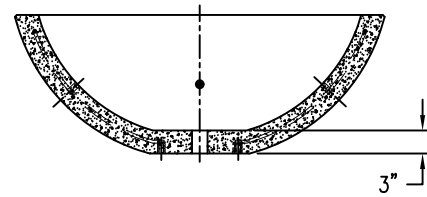

4 CROSS SECTION

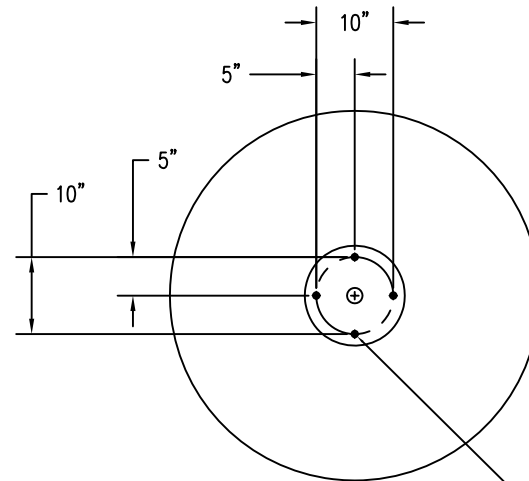

3 BOTTOM VIEW

(4) 1/2\"-13 UNC S/S INSERTS



REVISIONS

1	NAME	DATE	NOTES
2	---	---	---
3	---	---	---
4	---	---	---
5	---	---	---
6	---	---	---
7	---	---	---
8	---	---	---

CONFIDENTIAL INFORMATION
 THESE DRAWING, SPECIFICATIONS AND OTHER INFORMATION AND DOCUMENTS ACCOMPANYING THEM ARE THE CONFIDENTIAL AND PROPRIETARY PROPERTY OF WAUSAU TILE, INC. THE DRAWINGS THEMSELVES SHALL BELONG TO THE OWNER FOR USE ONLY ON THE PROJECT. ANY ADDITIONAL USE SHALL REQUIRE THE PRIOR WRITTEN APPROVAL OF WAUSAU TILE, INC. THE PROPRIETARY INFORMATION CONTAINED WITHIN THE DRAWINGS AND THE DOCUMENTS IS AND SHALL REMAIN THE SOLE PROPERTY OF WAUSAU TILE, INC.

JOB NAME

ADDRESS
 CITY, STATE ZIP

UNLESS OTHERWISE SPECIFIED
 DIMENSIONS ARE IN INCHES
 FRACTIONS ±1/8"

DRAWN BY: SK
 DATE: 7/13/15
 CO NUMBER: ?
 WEIGHT: 650 LBS

PRODUCT NO.
 TF 4106

REVISIONS

NAME	DATE	NOTES
1		
2		
3		
4		
5		
6		
7		
8		

CONFIDENTIAL INFORMATION
 THESE DRAWING, SPECIFICATIONS AND OTHER INFORMATION AND DOCUMENTS ACCOMPANYING THEM ARE THE CONFIDENTIAL AND PROPRIETARY PROPERTY OF WAUSAU TILE, INC. THE DRAWINGS THEMSELVES SHALL BELONG TO THE OWNER FOR USE ONLY ON THE PROJECT. ANY ADDITIONAL USE SHALL REQUIRE THE PRIOR WRITTEN APPROVAL OF WAUSAU TILE, INC. THE PROPRIETARY INFORMATION CONTAINED WITHIN THE DRAWINGS AND THE DOCUMENTS IS AND SHALL REMAIN THE SOLE PROPERTY OF WAUSAU TILE, INC.

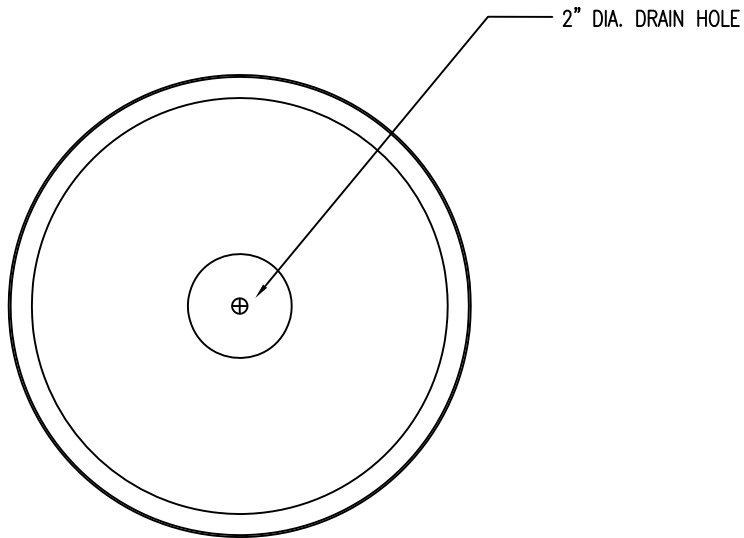

1 TOP VIEW

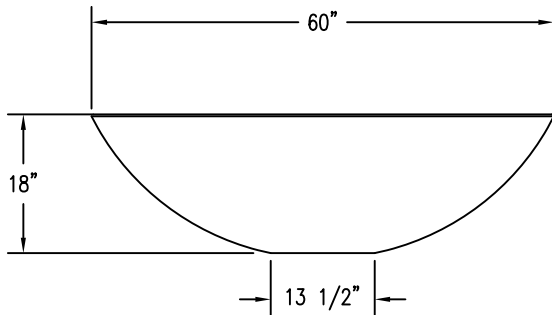

2 ELEVATION VIEW

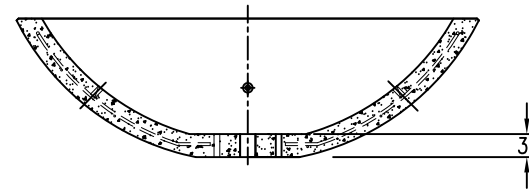

4 CROSS SECTION

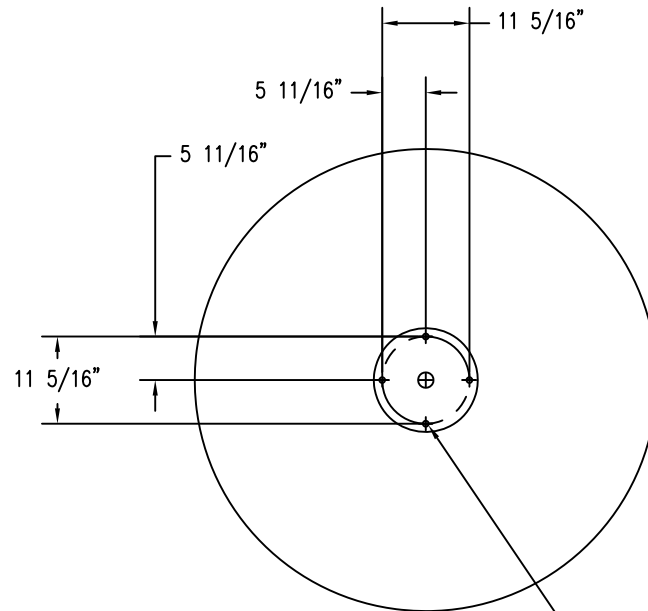

3 BOTTOM VIEW

(4) 3/4"-13 UNC INSERTS

JOB NAME
 ADDRESS
 CITY, STATE ZIP

UNLESS OTHERWISE SPECIFIED
 DIMENSIONS ARE IN INCHES
 FRACTIONS ±1/8"

DRAWN BY: SK
 DATE: 7/13/15
 CO NUMBER: ?
 WEIGHT: 900 LBS

PRODUCT NO.
TF 4128