

ROUND RACK



Simple. Stylish. Secure.

Clean lines and simple functionality make the Dero Round Rack welcome addition to bike parking. Much like a Hoop Rack, but with a more stylish appearance, the Dero Round Rack enhances public spaces while providing secure parking for two bikes.

PRODUCT & PRICING INFO CONTACT

 **STREETSCAPES**
STREETSCAPES.BIZ

Info@streetscapefurniture.com ■ 303.398.7040

ROUND RACK

YOUR LOGO HERE

Customize the Round Rack and brand your bike parking



FINISH OPTIONS

Galvanized Stainless



MOUNT OPTIONS

Surface

In-Ground

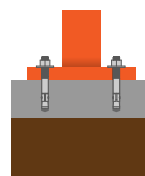

Powder Coat

White	Black	Light Gray RAL 7042	Deep Red RAL 3003	Yellow RAL 1023
CNH Bright Yellow	Orange RAL 2004	Blue RAL 5005	Sky Blue RAL 5015	Hunter Green RAL 6005
Light Green RAL 6018	Green RAL 6016	Sepia Brown RAL 8014	Bronze	Silver 9007
Dark Purple	Flat Black	Wine Red RAL 3005	Beige RAL 1001	Iron Gray 7011



Optional Lean Bar

ROUND RACK

Submittal Sheet

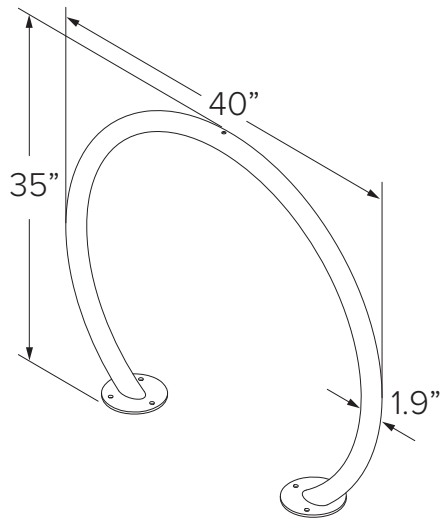

CAPACITY 2 Bikes

MATERIALS 1.5" schedule 40 pipe (1.9" OD)

- FINISHES**
- Galvanized**
An after fabrication hot dipped galvanized finish is our standard option.
 - Powder Coat**
Our powder coat finish assures a high level of adhesion and durability by following these steps:
 1. Sandblast
 2. Epoxy primer electrostatically applied
 3. Final thick TGIC polyester powder coat
 - Stainless**
Stainless Steel: 304 grade stainless steel material finished in either a high polished shine or a satin finish.

- MOUNT OPTIONS**
- In-ground**
In ground mount is embedded into concrete base. Specify in ground mount for this option.
 - Surface**
Foot Mount has two 6" circular feet with three anchors per foot. Specify foot mount for this option.

IN-GROUND MOUNT

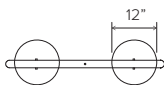

SURFACE MOUNT

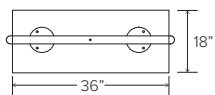

OPTIONAL LEAN BAR

- Add Lean Bar**

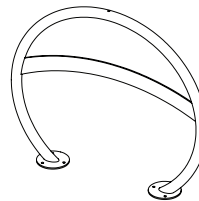
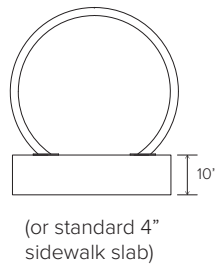
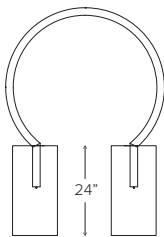

ROUND RACK

Setbacks

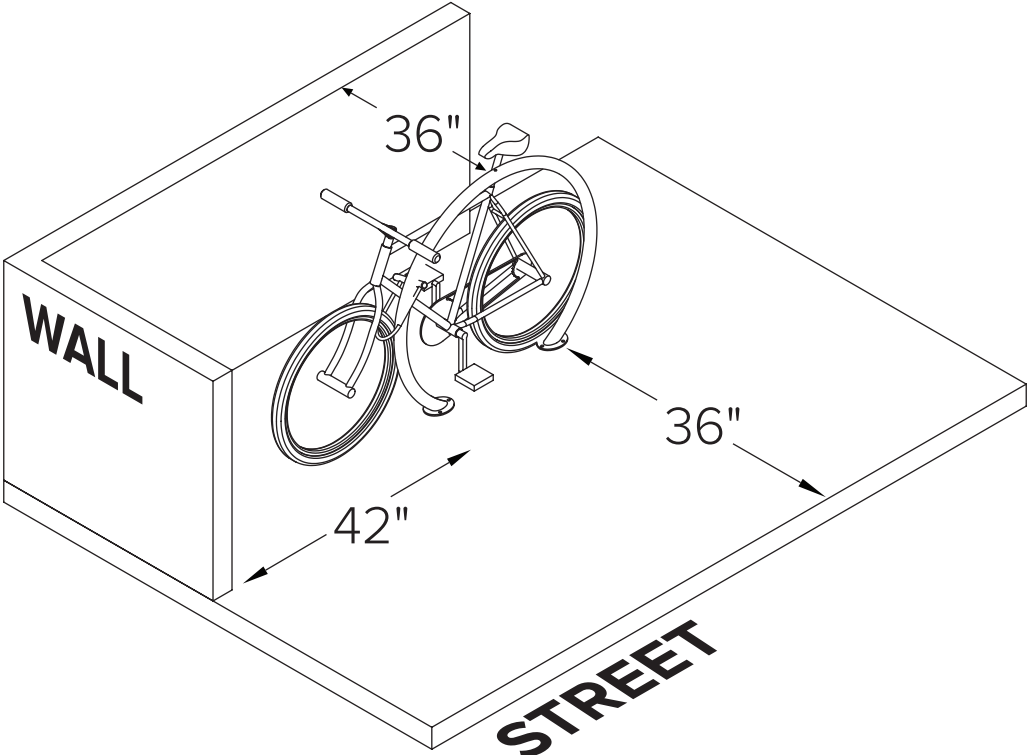

ROUND RACK

Installation Instructions – Surface Mount

TOOLS NEEDED

Tape Measure
Marker or Pencil
Masonry Drill Bit
Drill (Hammer drill recommended)
Hammer
Wrench 9/16"
Level

RECOMMENDED BASE MATERIAL

Solid concrete is the best base material for installation. To ensure the proper anchors are shipped with your rack, ask your Dero Rack representative which anchor is appropriate for your application. Be sure nothing is underneath the base material that could be damaged by drilling.

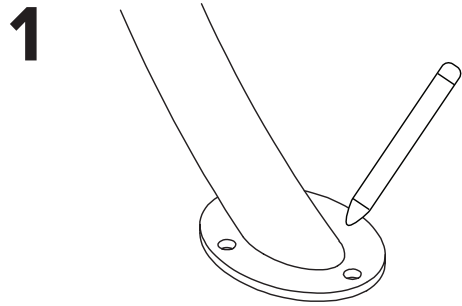

Place the rack in the desired location. Use a marker or pencil to outline the holes of the flange onto the base material.

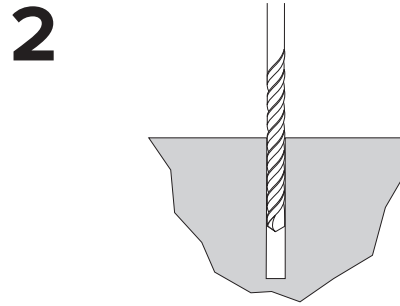

Drill 3/8" diameter holes 3" deep into surface. Make sure the holes are at least 3" away from any cracks in the base material.

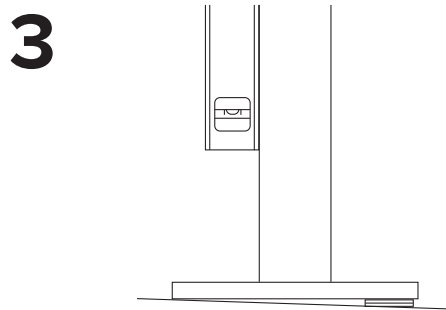

Place rack (and washers to level rack if necessary) over holes.

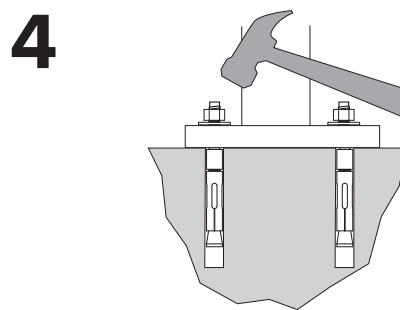

Thread nuts onto anchors, leaving approximately 1/4" of the anchor protruding, and tap into surface. Tighten nuts down to secure rack.

ROUND RACK

Installation Instructions – In Ground Mount

TOOLS NEEDED

Level
Cement mixing tub
Shovel
Trowel

Hole coring machine with 4" bit
Access to water hose
Materials to build brace (see "Install Tip" at bottom of page)

INSTALLING INTO EXISTING SIDEWALK

Core holes no less than 3" diameter (4" recommended) and 10" deep into sidewalk. Fill holes with Por-Rok or epoxy grout. Place rack into holes, making sure the rack is level. 33"-36" of the rack should remain above the surface. If the rack is less than 33" high, it will not support the bike adequately. Make sure the rack is level and held in place until the grout has set.

INSTALLING INTO A NEW SIDEWALK

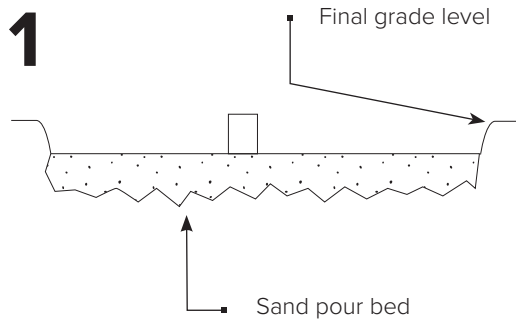

Place corrosion resistant sleeve (min. 3" inside diameter) in sand pour bed in exact location where rack will be installed. Make sure top of sleeve is at same level as desired finished concrete surface. Fill sleeve with sand to keep it in place and prevent it from filling with concrete.

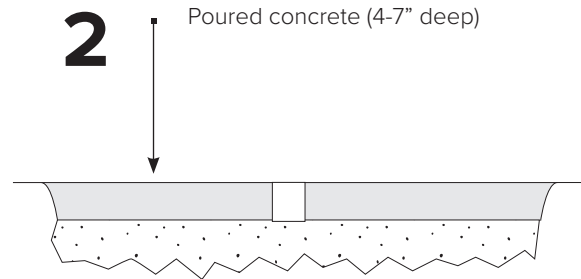

Pour concrete and allow to cure.

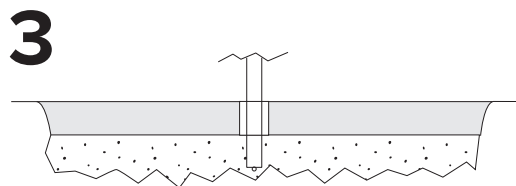

After appropriate cure time, dig out sand from sleeves and insert racks, making sure they are level and at the appropriate height. Pour in Por-Rok or epoxy grout and allow to set.

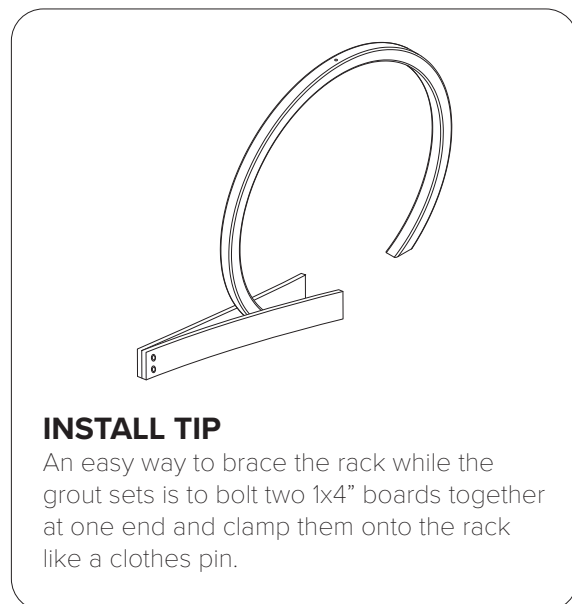

INSTALL TIP

An easy way to brace the rack while the grout sets is to bolt two 1x4" boards together at one end and clamp them onto the rack like a clothes pin.